

# Technology and System Layout of the Transrapid Maglev Project Munich

Christian Rausch

*Transrapid International GmbH & Co. KG, Berlin*

**ABSTRACT:** At the start of the project planning, the basic requirements for the project, like the future transport characteristics, the routing possibilities and the economical, ecological and safety features were summarized and analyzed. Connecting Munich Central Railway Station to Munich Airport, the Transrapid Maglev Project is expected to improve the traffic congestion between the busiest railway junction in Southern Germany and one of the most important air traffic hubs in Europe. Under the headline “in 10 minutes, every 10 minutes”, the operational parameters are defined in detail. In order to fulfil the needs of operation and maintenance as well, the track layout is fixed and adapted into the existing infrastructure and landscape.

The technical design for the maglev trains, the propulsion system, the energy supply and the operation control system as well as the layout of the stations and the maintenance facilities are developed based upon the project-specific operations and safety concept. Ensuring safe and reliable operation with an environmentally friendly layout, the decisive prerequisites for the certification and approval of the Transrapid Maglev Project in Munich are thereby established.

## 1 INTRODUCTION

Connecting Munich Central Railway Station to Munich Airport, the Transrapid Maglev Project is expected to improve the traffic congestion and to provide for a fast and convenient transportation link between the busiest railway junction in Southern Germany and one of the most attractive air traffic hubs in Europe (*figure 1*). With a trip time of 10 minutes and a headway of 10 minutes the Transrapid is the only suitable transportation means to satisfy the challenging project requirements.

## 2 SYSTEM ENGINEERING

Transrapid International (TRI) is in charge of the system planning for the project. Together with Siemens and ThyssenKrupp the system engineers of TRI are responsible for the technical layout work especially concerning the

- trains
- propulsion and energy supply system
- operation control system
- guideway.

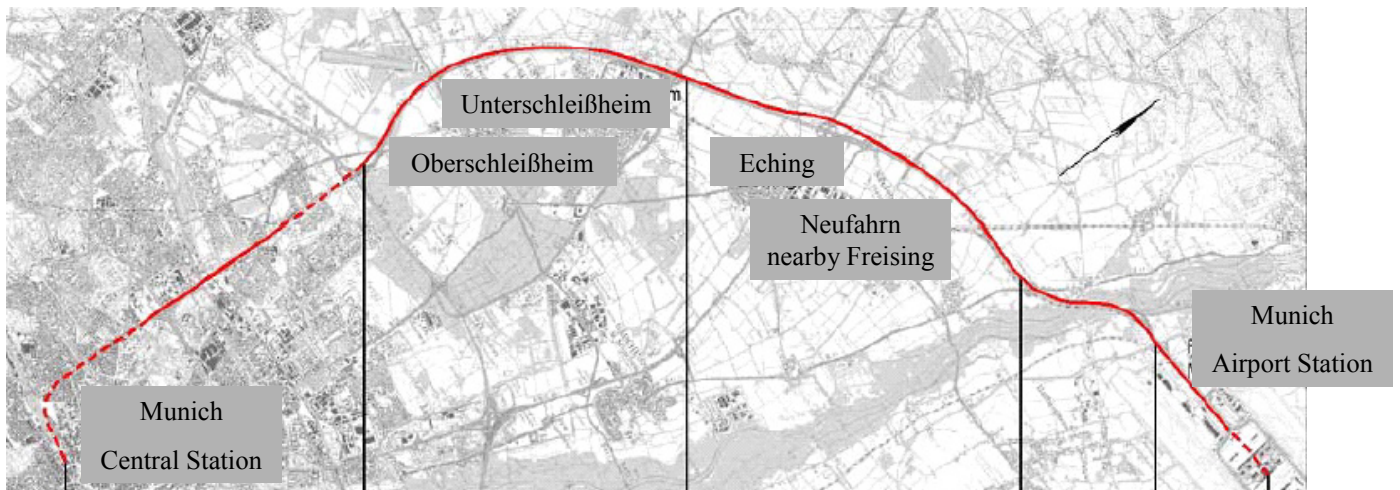

Figure 1: Route

In addition to the system layout, the adaptation of the maglev system into the existing infrastructure and especially the environmental impacts of the project were carried out by various experts and institutions.

TRI also carried out the conceptual design of the operation and safety of the maglev system. In close cooperation with the customer, DB Magnetbahn GmbH, the maglev subsidiary of Deutsche Bahn AG, the project requirements were analysed.

### 3 TECHNICAL LAYOUT

#### 3.1 Track Scheme

On the basis of the route defined during the regional planning procedure, the project contains two maglev stations at

- Munich Central Railway Station and
- Munich Airport,

a double track guideway approximately 37 km long, two substations for propulsion and energy supply, a maintenance centre with five tracks, and the operation control centre.

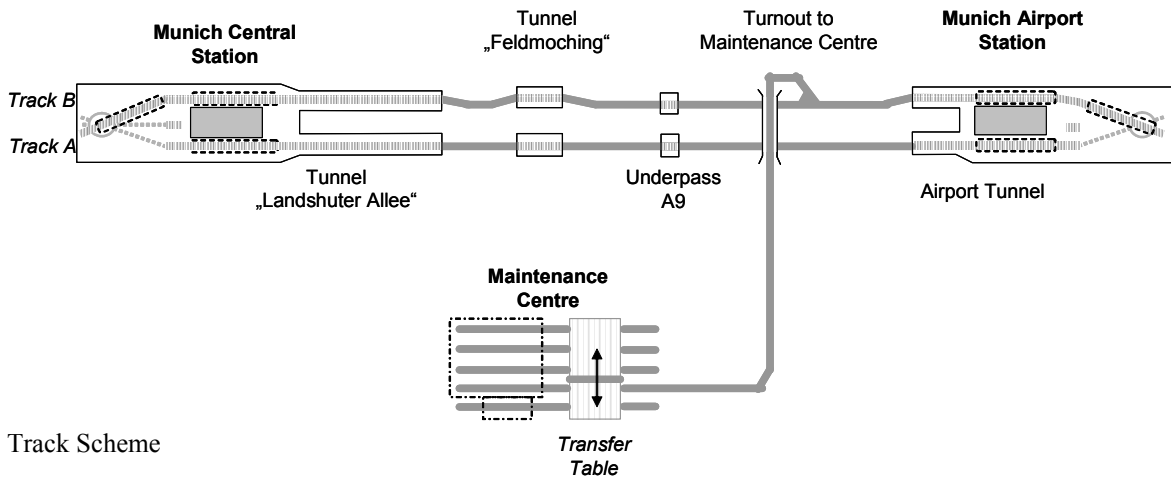
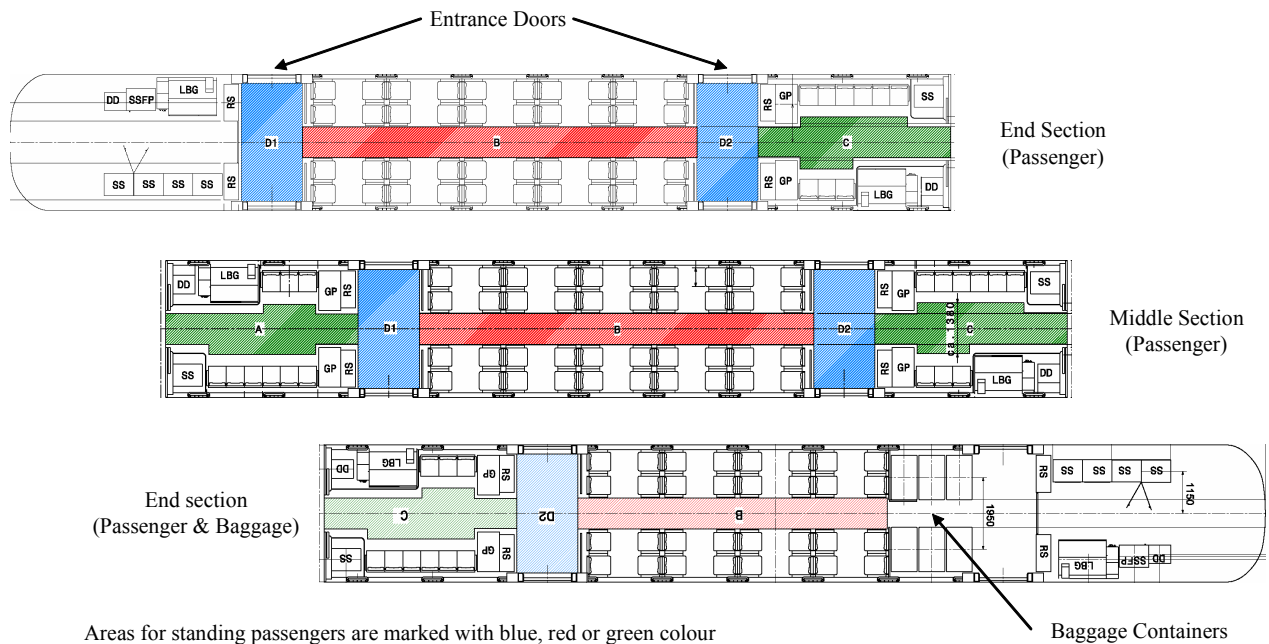

Figure 2: Track Scheme



Areas for standing passengers are marked with blue, red or green colour

Baggage Containers

Figure 3: Train Configuration

Furthermore all maglev related data for the legal planning procedure was provided. Special attention was paid to system data for the assessment of the environmental compatibility as well as for the operation and maintenance of the maglev system.

Both stations are situated underground. Most of the route alignment is at-grade. And there are three tunnels with a total length of nearly 9 km.

#### 3.2 Train Configuration

Special requirements of this airport link call for new solutions for the vehicle layout (Rausch & Jung 2003):

- an increased vehicle load allows for a greater passenger capacity (with sitting and standing passengers)
- an increased width of the vehicle entrance doors facilitates fast and easy boarding and alighting
- a separate container compartment allows for simultaneous luggage transportation (check-in already at Munich Central Station)

Taking into account the above mentioned requirements the resulting train configuration consists of train set of three vehicle sections with a passenger capacity of up to 148 seated and 265 standing passengers and 2.45 t baggage in up to seven containers.

As with the vehicle, special attention has been paid to the design loads of the guideway and the interaction between vehicle and guideway (Schwindt et al. 2004).

### 3.3 Propulsion Configuration

The propulsion layout has to take into account the trip time of less than 10 minutes as well as the stability of the operation with four trains and a headway of 10 minutes.

The speed profile is limited by the route alignment constraints and by the speed limitation for tunnel sections. A maximum operating speed of 350 km/h allows a trip time of less than 10 minutes as well as meeting the economical and ecological aspects of the project.

The resulting propulsion layout consists of six propulsion segments for the main tracks which are powered by high power propulsion blocks and one propulsion segment fed by a low power propulsion block for the maintenance area. The propulsion blocks for the main tracks are laid out redundantly.

### 3.4 Operation Control Configuration

The operation control system is divided into segments corresponding to the propulsion segments. These propulsion and operation control segments have been optimised in order to ensure a headway of 10 minutes with adequate buffer times (Rausch 2003).

## 4 OPERATION

The layout of the system has been optimised for a trip time of less than 10 minutes for a single trip between the stations. With an operating speed of 350 km/h in this project, the dynamic parameters fulfill all comfort criteria.

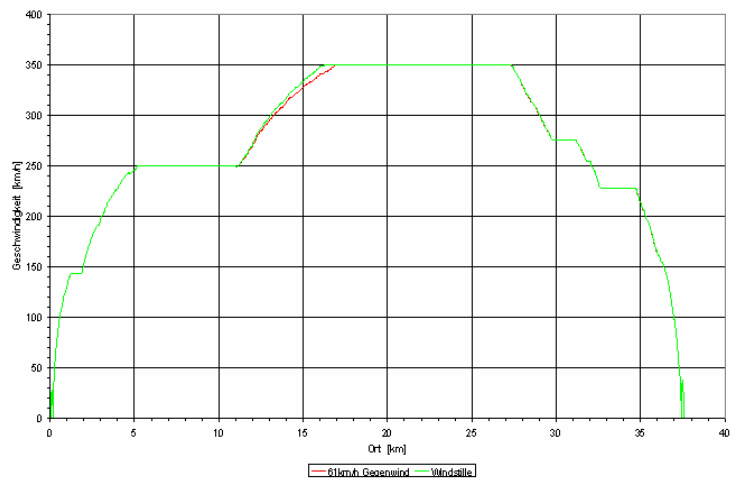

Figure 5: Speed Profile with/without head wind (example)

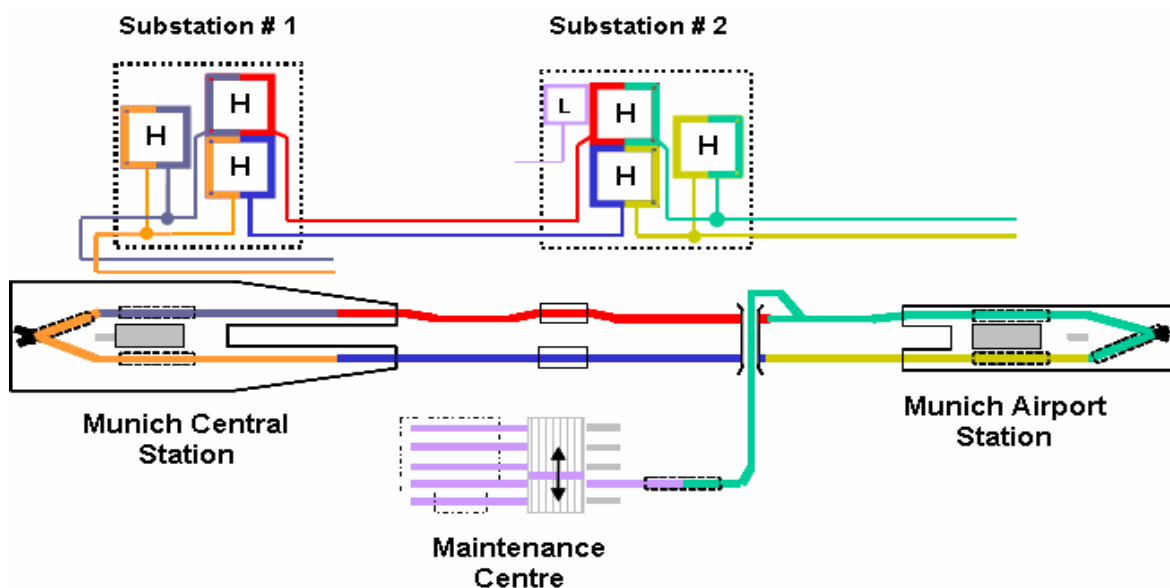

Figure 4: Propulsion Layout

The operating hours of the regular schedule are shown in *table 1*.

Table 1: Operating Hours

Operating Hours	Headway
04:00 – 05:00	20 minutes
05:00 – 23:00	10 minutes
23:00 – 24:00	20 minutes

The headway and the train configuration are in accordance with the ridership prognosis of 7.99 Mill Passenger trips per year in 2015.

When combining single trips to an operations schedule, the following data have to be considered (Rausch et al. 2005b):

- Time to board the train: one passenger per second and entrance door
- Time to change over from one track to the other: 1 minute
- Departure time at xx:10, xx:20, xx:30 ...
- Sufficient and balanced buffer times

This results in a regular station dwell time of minimum 2.5 minutes and the possibility to flexibly choose an operation schedule mode as shown in *figure 6*.

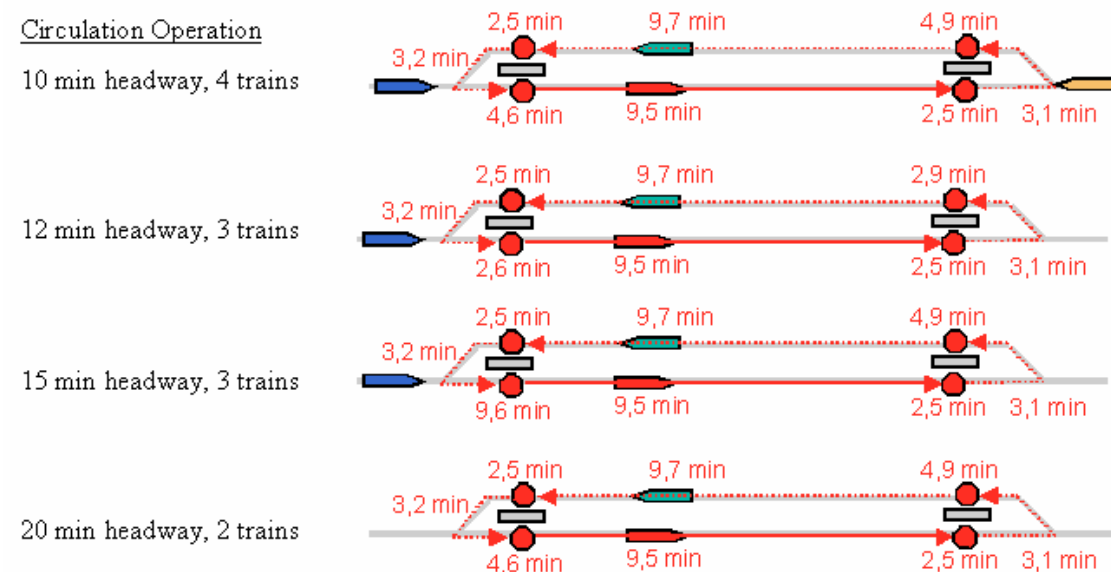

Figure 6: Operation Schedule Modes

## 5 SAFETY AND APPROVAL

The Maglev System Construction and Operation Ordinance (Magnetschwebbahn Bau- und Betriebsordnung, MbBO), which is Article 1 of the Maglev System Ordinance, regulates the responsibility of the Federal Railway Authority (EBA) for planning permission, approval, and as supervisory authority for maglev systems in Germany (Rausch et al. 2004).

The Transrapid Maglev System technology is subject to a systematic analysis and permanent testing with special regard to safety. Test runs and proofs are conducted at the Transrapid Test Facility in Emsland, Germany (TVE).

Apart from existing Norms and Standards, Technical Standards for the Maglev System have been developed to serve as a basis for the approval of the Transrapid technology. EBA will check the project layout against the requirements stated in the Technical Standards. The approval procedure is explained in detail in (EBA 2004).

The MbBO demands fulfilment of the defined protection objectives. However, it does not regulate how and with which means these objectives are to be achieved and in particular, it contains no constructive requirements. According to the MbBO, it is the responsibility of the maglev project owner to identify and assess all detectable safety risks by means of risk assessment and to describe them by kind, frequency, and effects. The project owner has to define the necessary construction, operational, and organisational safety measures. These safety measures must be incorporated into a safety concept which has to be approved by EBA (Rausch et al. 2005a).

Safety assessment is carried out by the EBA or acknowledged experts approved by the EBA (Rebentisch & Meine 2003). Based on the proof of safety, on the rules and regulations, and on the performance during the trial operation, an operating licence for commercial operation will be granted by the EBA.

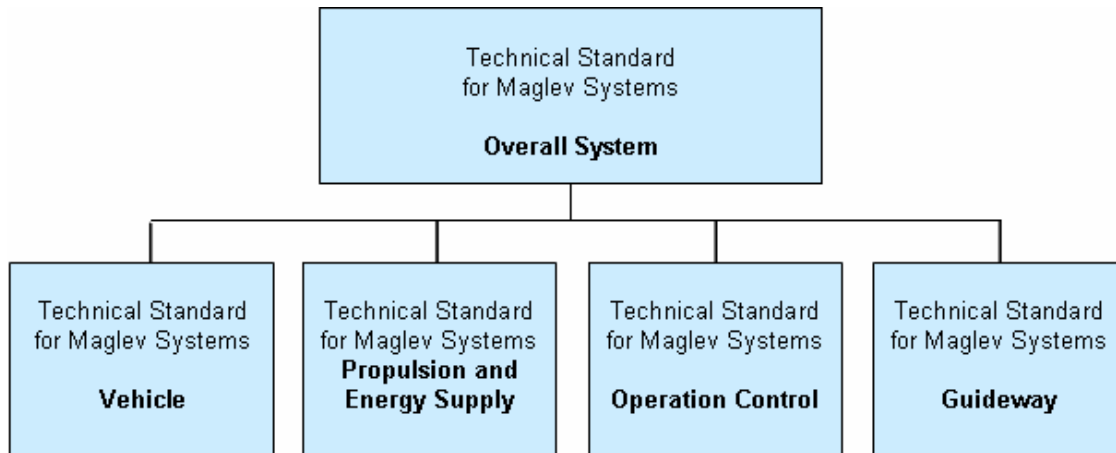

Figure 7: Technical Standards for Maglev Systems

## 6 REFERENCES

- EBA. 2004. Approval of Operation Facilities and Trains according to § 6 Maglev System Construction and Operation Ordinance. *EBA-Leaflet*. 08/2004, Bonn
- Rausch, Chr. & Janssen, T. & Zaiser, I. & Gmünder, F. & Hürzeler, Chr. 2005a. Safety Concept for the Maglev System Transrapid. 5. *Dresdner Fachtagung Transrapid*. Dresden
- Rausch, Chr. & Fischperer, R. & Schwanck, St. 2005b. Operations Concept for the Maglev System Transrapid. 5. *Dresdner Fachtagung Transrapid*. Dresden
- Schwindt, G. & Hauke, U. & Fried, A. 2004. Interaction Vehicle / Guideway, Guideway Design aspects for the Munich Airport Link, MAGLEV 2004, Shanghai
- Rausch, Chr. & Janssen, T. & Kokott, J. 2004. The Transrapid Munich Airport Link – Operation, Safety and Approval. *MAGLEV 2004*. Shanghai
- Rausch, Chr. 2003. System Engineering of the Transrapid Maglev System (Systemtechnik der Magnetschnellbahn Transrapid), *ZEVrail*, October 2003.
- Rebentisch M., & Meine, K. 2003. Preconditions for putting into service a Maglev Line, *ZEVrail*, October 2003.
- Rausch, Chr. & Jung, A. 2003. Weiterentwicklung der Magnetschwebbahn Transrapid für neue Einsatzfelder, *El. Bahnen*, 2003 (1-2).