

Current Status of Maglev Development Programme

Gunter Nissen

Dornier Consulting GmbH, Berlin Office, Germany, gunter.nissen@dornier-consulting.com

ABSTRACT: In 2000 the German Ministry of Transport, Building and Urban Affairs (BMVBS) announced a development programme for the optimisation and application-oriented development of the maglev technology. Since August 2002 the emphasis of the development programme, which has been commissioned by the BMVBS following an EU-wide tender, has been on two main topics, the new development of cost-optimised guideway beams and the further development of system technology. The main objective of the development project ‘cost-optimised guideway beams’ is the new development of technically improved guideway beams and the achievement of significant cost reductions compared to the existing guideway beam types. The main goal of the project ‘system technology’ is the further development and implementation of potential cost reductions for the subsystems vehicle, propulsion, operations control system and power supply. The proposed development projects will contribute to an increase of market acceptance of maglev systems all over the world as well as to the realisation of the proposed Munich line, and to secure jobs for highly qualified professionals and know-how of the German systems industry. An overview of the main objectives, structure and contents of the development programme are given.

INTRODUCTION

Originally the magnetic levitation (maglev) technology has been developed for long distance travel. Following the stop of the Berlin – Hamburg project in 2000, investigations of future markets for the application of maglev technology have shown that besides the long distance option other application areas exist, i.e. high-performance point to point connections with a premium product. And this appeared to be true not only for applications in Germany. In other countries such as the U.S.A. such applications also seemed to offer sound marketing opportunities

In order to encourage these new application opportunities the BMVBS has established a research and development programme with the main emphasis on system technology and guideway. Because at that time the available maglev system could not fulfil the technical requirements for a modern means of transport for regional travel. In the process the contents of the development programme was defined in a way that any development would benefit almost all further applications. Improvements resulting from the adaption of the system to regional transport especially availability and cost reductions would be able to be transferred to other application areas. This should be facilitated by a platform concept.

Specific issues were investigated with the main goal of achieving the following items in the vehicle,

propulsion and power supply subsystems, the operations control system and guideway subsystems:

- Adjustment of the maglev technology to regional transport requirements.
- Reduction of the capital and operational costs.
- Elimination of remaining development problems.

1 OBJECTIVES OF THE DEVELOPMENT PROGRAMME

The world-wide first commercial maglev line in Shanghai is based on long distance travel requirements with a technical state of the year 2000. The innovation cycle in the technology sector takes less than five years today. For this reason and in light of an international marketing of German technology it seems justified to contract a project to safeguard the functionality of a technically and economically optimised maglev systems by the public authorities. Technical improvements through fewer components, ease of change of components, a more robust design against environmental influences, an increase of passenger comfort and an adjustment to higher traffic loads as well as the implementation of potential cost reductions both for the investment costs of the operational system and the guideway and for operational and maintenance costs over the life cycle of the maglev system describe the main objectives for his contract. As a result a long-lasting, durable and

world-wide applicable maglev system will be developed, which will among other things afford longer reinvestment cycles.

2 STRUCTURE OF THE DEVELOPMENT PROGRAMME

Cost-optimised guideway beams	Further development of system technology
New development of the guideway beams includes four phases: I Negotiation process, in two steps (basic concepts and draft design) II Development and construction III Manufacturing of prototypes IV Certification process	Project system technology is divided into four phases: I Concept II Development and construction III Prototype manufacture IV Type certification

NEW DEVELOPMENT OF COST-OPTIMISED GUIDEWAY BEAMS

The new development of cost-optimised guideway beams was initiated in order to further develop the maglev track, with special emphasis on the requirements of regional transport links.

The further development of guideway beams and track elements for maglev technology of the Transrapid type should lead to an improvement and significant cost reductions of the guideway, in comparison to the track types that had been qualified for the Berlin-Hamburg line.

As a result, the BMVBS will acquire the commercial rights for two more maglev tracks (Type II and III) and will be able to use these rights in Germany and in the EU, and in order to implement maglev systems transfer these rights to the supporting agency of the project.

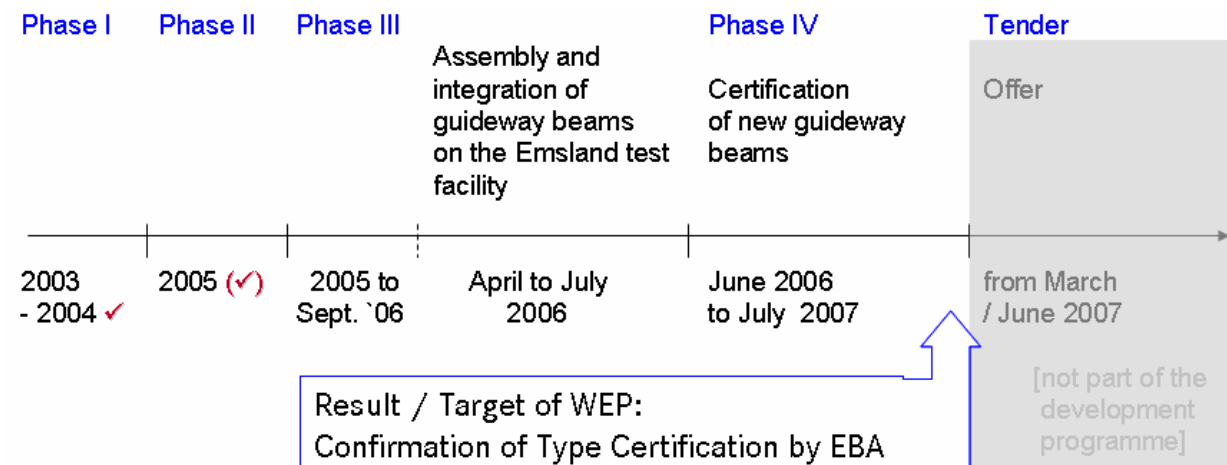

The project is to be completed in the second quarter of 2007. The project time line is shown in Figure 1.

FURTHER DEVELOPMENT OF SYSTEM TECHNOLOGY

In the context of further development of system technology, the entire system, including its subsystems, must be modified to suit its application as high-performance point to point connection, i.e. the linkage of airports to the city. Furthermore it is an equally important goal to significantly improve the economics of the maglev system through further development. The modified technology should provide a cost-optimised, ready-to-implement, functional solution. The development programme system technology consists of four phases. In Phase I (Concept) all necessary activities were defined, which in the subsequent project phases (Phases II to IV) would lead to the achievement of the required functions for the maglev system, to use the system as a regional mode of transport and the certification by the Federal Railway Authority. This was carried out by comparison of the new requirements with existing maglev technology and subsequent prioritisation of necessary improvements.

The phases Concept and Development and Construction are more or less completed. In 2007 the most important works with regard to testing and operation will be carried out at the Emsland Transrapid Test Facility. It is expected that the project will be completed in the 3rd quarter of 2008.

Figure 1: New development of cost-optimised guideway beams – Multi-level process in four phases.

3 CONTENTS OF THE DEVELOPMENT PROGRAMME

NEW DEVELOPMENT OF COST-OPTIMISED GUIDEWAY BEAMS

Phase I – Negotiation process

Level I: Basic concepts

- New or improved design of guideway beams Types I, II or III, which leads to a significant reduction in costs.
- Description of the design concept of manufacture and assembly of track components, as well as transport and on-site assembly as required.
- Description of development needs and steps through to construction.

Level II: Design and preparation of tender for the next phase, including prices.

- Development of optimised maglev guideway beams on the basis of the basic concepts.
- Proof of fulfilment of the structural and dynamical requirements
- In-depth analysis of manufacture and life-cycle costs
- Preparation of technical and financial offer for the execution of Phase II and the optional Phases III and IV.
- Preparation of draft schedule for Phases II to IV.

The track designs, which were prioritised in the context of the negotiation process (see Figure 2 and 3), will be designed, manufactured, tested and certified by the firms of the bidding consortium of medium-sized companies (BGmU) and Ed. Züblin AG.

Phase II – Development and construction

- Building and approval procedure, negotiations for type certification and operational approval for the Emsland Transrapid Test Facility
- Development and implementation of a track of Type I, II or III.
- Technology and processes for the manufacture and assembly of prototypes at test facility.
- Concept of manufacture for mass production
- Concept for transport construction and assembly on site for a maglev line
- Test of track components on a test bench

Phase III – Manufacturing of prototypes

- Planning of the procurement and manufacturing processes to completely construct the chosen designs
- Supplementary test runs for track components on the test bench
- Manufacture of at least one curved and straight section of each Type
- Manufacture and adjustment of the support structure of the track at the Emsland Transrapid Test Facility
- Rigging, delivery, integration and operation of prototype guideway beams

Phase IV – Certification process

- Trials of guideway components on the test track.
- Theoretical and practical verification (structural testing of the track types)
- Preparation of type certification documents (drawings and reports)
- Assurance of type certification in accordance with Paragraph 6 of the MbBO

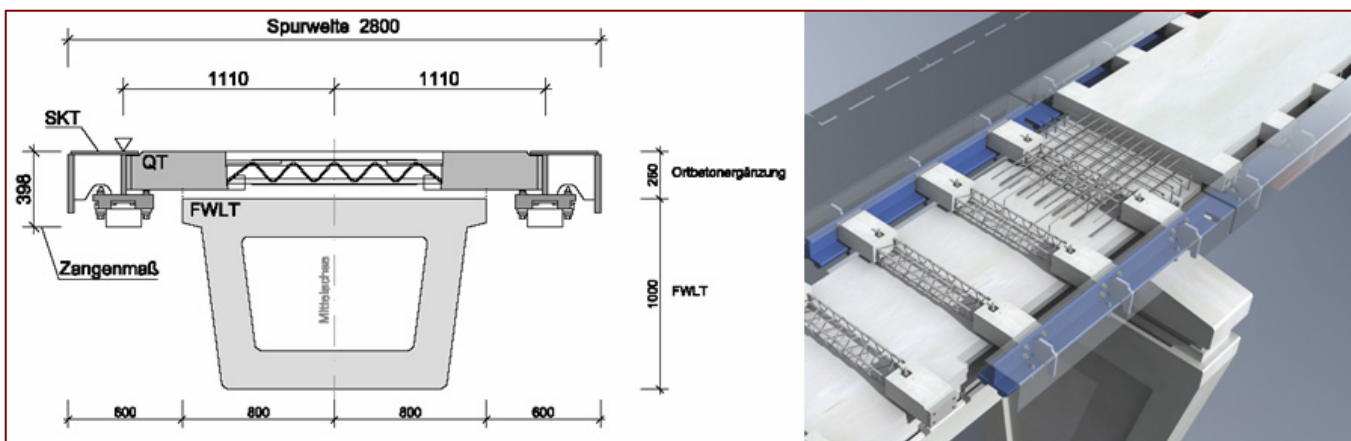

Figure 2: Track of Type II, BGmU design (Source: BGmU)

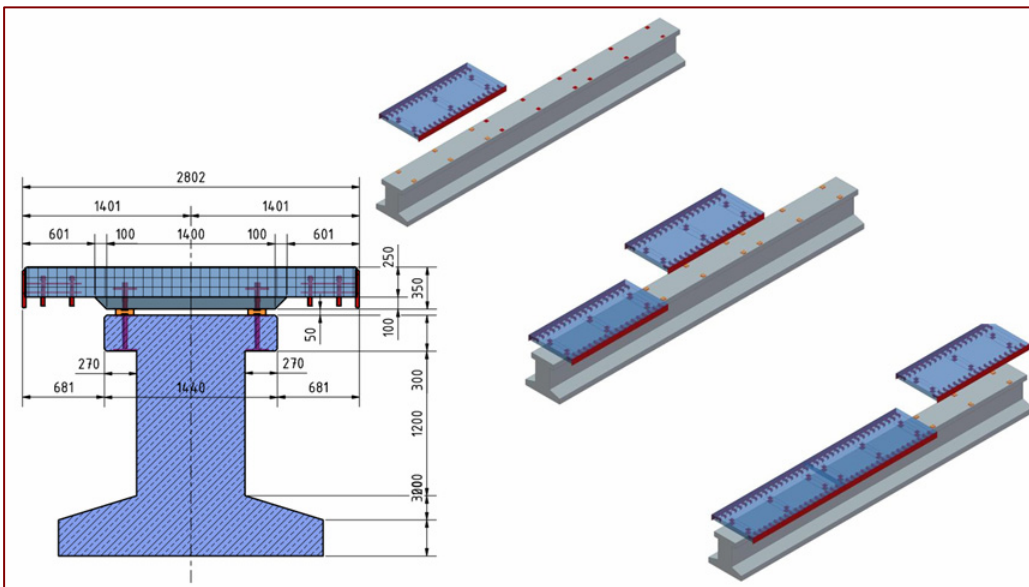

Figure 3: Track of Type III, Züblin design (Source Züblin)

FURTHER DEVELOPMENT OF SYSTEM TECHNOLOGY

In addition to project management, during the concept phase twelve tasks were identified, which should be carried out during the course of the project:

- Preparation of new implementation guidelines (leads to national Maglev standards)
- Systems integration
- Guideway beams
- Reduction of length of safe stopping segment and reduction in false acceleration
- Guideway switches
- Standardised converter unit
- Hardware innovation propulsion control
- Segment boundary overlap
- Radio transmission system
- Three section vehicle TR09
- Operations control system for the TR09 vehicle
- Inductive power supply (IPS)

Systems integration

Systems integration bundles all those activities which concern more than one subsystem at the same time. The following topics are being described:

- Systems Verification

The documents, which were produced during the development programme on a subsystem level, are being verified on the systems technology level from a comprehensive systems view

point as well as for conformity to the other developments within the programme and for interface compatibility.

- Certification of entire system

The required processes and certifications to achieve licensing according to Paragraph 6 of the MbBO are collated in a certification concept.

- System interfaces

During the implementation of the development topics, the systems interfaces are considered from the viewpoint of the entire system and, if necessary, changes are initiated. Interface responsibilities are documented.

- Operational concept - incident management

This concept includes process-oriented analysis of disruptive elements and influential factors, surrounding conditions, as well as the operational requirements and processes, which focus on the uninterrupted operation, irrespective of a specific project.

- Adjustment of Emsland Transrapid Test Facility

Verification, and if necessary, new proposal, of stopping points of the Emsland Transrapid Test Facility based on the changed input data, which were derived from development program measures.

- Safety certification of the Emsland Transrapid Test Facility

Support of the holder of the operational licence for the Emsland Transrapid Test Facility, with regard to the safety certificates of the entire system by collating of the safety certificates of the systems development programme measures.

- Confirmation of system functionality

Proof of system functionality after successful start of operation of each separate development program measure on the Emsland Transrapid Test Facility.

Guideway beams

In the development project “New development of cost-optimised guideway beams”, potential optimisation measures of the beams were investigated and further developed. Furthermore development topics for guideway beams were identified and summarised in the form of work packages in the technical scope of the development programme systems technology.

- Technical inspection of guideway beams in the context of the whole system

Certification for existing steel guideway beams on the basis of the new implementation guidelines.

- Support of system technology issues of the development program “New development of cost-optimised guideway beams”

The task includes the support of development, construction, testing and certificates of two guideway beam types, which are manufactured by Züblin and BGMU.

In Phases II to IV the contractor companies need to be further supported with regard to system technology issues. Furthermore, the structures must be checked with regard to systems technology and proposals need to be made for best installation locations for rigging equipment. Installation of the prototype guideway beams, and the commissioning has to be supported from the systems technology end.

Reduction in length of safe stopping segment and reduction in false acceleration

A paramount objective is the qualification of a technical solution to reduce the length of the safe stopping segment, which

- enables shorter safe stopping segments in the terminal stations, maintenance and parking facilities, or
- achieves travel time savings through minimisation of the time lack from command prompt until command execution

- permits smaller stations, especially within tunnel solutions, and
- enables the reduction of the capital costs.

The desired goals include a significant potential to improve with regard to the investment and operational concept. In addition there is an important requirement for the Munich project, namely, adherence to the target travel time of ten minutes. This measure makes a significant contribution to reaching this goal.

Guideway switches

In view of the creation of a long-lasting, low maintenance and durable product and taking into account the requirements of guideway switches based on the track diagramme of the Munich project it was determined that the in Shanghai installed low speed switches cannot fulfil the technical requirements of regional transport.

As part of the development, the type catalogue of guideway switches and track-changing facilities (transfer tables and pivot tables) is being expanded. The switches and track changing facilities need to be designed for higher operating load. Furthermore the increases in availability and also in reliability are important criteria. Finally the reduction of the maintenance and inspection efforts to enable night operations and thereby improvements in economic efficiency are important development tasks.

Standardised converter unit

The objective of the further development of the converter unit, being a central function of the propulsion block, is the development of a standardised conversion unit, with the following improvements to functions and interfaces while retaining the type-certification:

- Expansion of the existing converter unit concepts with the power network regeneration function.
- Replacement of the Transrapid-specific power section of the converter unit, through integration of an industry-standard power converter on the basis of integrated gate commutated thyristors (IGCTs) into the existing converter unit.
- Consideration of requirements stemming from the concept for overlapping propulsion sections (segment boundary overlap) and new concepts for safe stopping segments, respectively.

Hardware Innovation Propulsion Control

Die propulsion control software is dimensioned for the currently-used but in the meantime outdated system SIMADYN D. Therefore a transfer of the existing functionality of SIMADYN D to the new plat-

form must be carried out. At the same time, further development will be carried out, which is based on the experience with the current use of the system and the existing functions and is optimised for the proposed use. In addition new functions will be integrated, which are derived from detailed requirements from proposed projects, such as power regeneration, section overlap and track turnouts.

Following successful further development a system will be available, which stands at the beginning of a product life cycle and because of the use of industry computers will be less susceptible to product recalls. The performance of the system meets the requirements of short and long distance travel and offers numerous advantages:

- Better communication enables new line concepts and a simpler remote maintenance and diagnosis of the facility,
- Open technology, which enables easier adjustments to new requirements,
- Standardisation of the propulsion control hardware and the resulting simpler maintenance and provision of spare parts,
- Increase of availability of control systems through reduction of elements with retention or improvement of the mean times between failures (MTBF) for individual elements.
- Good value technology through a high number of elements from the usual business,
- Long-term availability.

Section overlap

The structure of the operations control system (and the radio control system) will not be changed from its existing state. The hierarchical structure, containing central and decentralised facilities as well as vehicle components, and for the radio frequency system radio base stations, will remain the same. The operations control system will be expanded to include the functions section overlap (or segment boundary overlap) protection, safeguarding of the safe stopping segments, and the radio communication system will be expanded by a tunnel-specific system.

The section overlap has the purpose of assigning a vehicle at a section border or in close proximity of the section border to the neighbouring section so that a vehicle can be registered in the neighbouring section earlier and it is possible to reduce the time between trains.

Section overlap will be used where the dwelling time of a vehicle in one section is longer than in other sections, for instance in stations or at the entrance to long sections along the line. Another appli-

cation results from the coupling of stations at section borders to reduce the number of auxiliary stopping areas and thereby reduce the expense of track equipment (for instance, external vehicle power supply).

Radio communication system

With future Transrapid applications it is to be expected that the track will be at least partly in deep cuts and next to high noise and view protection barriers, or in tunnels.

The objective of the development program for the radio communication system (tunnel: maintenance, diagnosis and base station) is the optimisation of characteristics of the radio communication system regarding its use along lines with tunnels.

Through an optimisation of the maintenance concept of the guideway equipment of the radio communication system, a possibility should be found to guarantee a comparable availability of the radio communication system even with possible restrictions in tunnel sections, with the help of alternative concepts. Thereby, an effect on the operations by urgent maintenance requirements in the tunnel can be largely avoided.

This new concept should achieve an improvement of the diagnosis. A key point is thereby the identification of a fault independently of the hardware component to be checked, in order to increase the rate of fault detection. This would lead to savings in personnel costs because of shorter call-out times.

At the tunnel entrance and in the tunnel, a much higher air pressure and vortices must be expected from passing vehicles than away from tunnel structures. These issues should be taken into account as part of an analysis and adjustment of the in-vehicle antenna enclosures to guarantee an optimised and undisturbed operation in tunnel sections.

TR09 three-section vehicle

Important requirements of modern means of mass transport are the support of the alighting/boarding process through optimal position and width of the doors and the ability to adjust the transport capacity through provision of both seating and standing passenger spaces to the distinctive transport demand curve.

The requirements in the context of the development programme are a resulting combination of, firstly, typical characteristics of regional transport (wide entrance doors in the middle of the car, accordingly adjusted design of air-conditioning ducts, increased operating load with use of standing spaces) and, secondly, the requirements of high-speed long distance transport (pressure-sealed design of the car with corresponding integration of air-

conditioning units, low level of interior sound and sound emission to the exterior, consideration of luggage transport, as well as running resistance and power demand).

At the same time an economically-efficient use of the vehicles, on the basis of transport capacity and the kilometres driven per vehicle per year, should be achieved.

The Transrapid TR09 belongs to a new generation of vehicles which is especially tailored to the requirements of regional transport. Higher load for the transport of more passengers, wider doors to speed up alighting and boarding, bigger interior vehicle height to provide a pleasant journey for standing passengers, new air conditioning technology. The TR09 is the prototype vehicle for the Munich Transrapid project.

Operations control system for the TR09 vehicle

The supply of an operations control system for the TR09 is linked to the development and realisation of the maglev vehicle in the development programme.

The objective of this development program measure is the manufacture, assembly and implementation of the operations control system for the TR09, so that the vehicle can be secured for the operation on the Emsland Transrapid Test Facility.

Inductive power supply (IPS)

Taking into account the economical use of the available on-board network batteries (life cycle, maintenance interval, maintenance effort) it is necessary to prevent stressing the batteries, if possible, with discharge-charge-cycles during normal operations of the Transrapid vehicle. Consequently an external stationary on-board power supply is required in the station areas and in parking and maintenance facilities.

Until now, external power supply was realised by conventional technology (collector, feeder power rail). Known problems of conventional systems (wear and tear, noise, sparks) as well as the break of the system by contact (levitating inductive train system) are remedied by the use of inductive power supply.

4 CURRENT SITUATION AND OUTLOOK

NEW DEVELOPMENT OF COST-REDUCED GUIDEWAY BEAM

- Development phase is completed.
- Manufacturing, outfitting/rigging, delivery, on-site assembly and operations of the prototype beams are completed.

- Long-term tests of prototype beams on Emsland Transrapid Test Facility are currently being carried out.
- Long-term tests are expected to be completed in the second quarter of 2007.
- Completion of preparation of documents for the type certification is expected in the second quarter of 2007

4.1 FURTHER DEVELOPMENT OF SYSTEMS TECHNOLOGY

- Concept phase is completed
- Development phase of single measures will be completed shortly.
- Qualification of elements is completed
- Assembly and operation of elements and systems on the Emsland Transrapid Test Facility have started.
- Manufacture of vehicle prototype TR09 at the Emsland Transrapid Test Facility has progressed to a large degree.
- Commissioning of the TR09 prototype at the Emsland Transrapid Test Facility is expected from April 2007.
- Test and operation of subsystems and the entire system planned for 2007
- Certification of systems functionality is expected October 2007 – January 2008

With the development programme the BMVBS significantly supports the development and optimisation of many components of the maglev systems for an application as premium product in regional and point-to-point travels. Thereby it is possible to open up new opportunities on a worldwide market to use this innovative, technically mature product.

5 GENERAL CONDITIONS/ SUPPORTING ACTIVITIES

In order to summarise the existing results from the development, testing and approval procedure of the maglev guideway and systems technology a standardisation process has been started, which will ultimately lead to state-of-the-art standards for maglev systems (see Figure 4). These will define the technical and operational specifications of maglev systems and will form the basis for planning, design, implementation and the operation of maglev projects.

The required steps are the preparation and sign-off of implementation guidelines (state of the art

standards) in draft format, supported by experts from the Technical Committees (similar to the DIN-process 820) as well as publication by the Federal Railway Authority. This step has been completed on 26 April 2006.

After the three-month public comment period, a review of the comments received and, if necessary, the development of solutions, are carried out as part of the finalisation of the documents in the Technical Committees. The documents are then signed off by the Technical Committees.

Subsequently the implementation guidelines are published by the Federal Railway Authority as state-of-the-art standard and are binding for maglev systems in Germany.

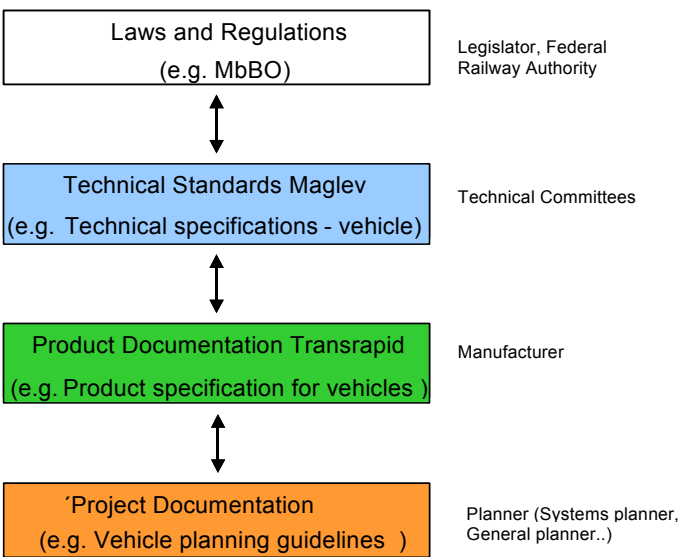

Figure 4: Document levels (Source: Transrapid International GmbH & Co. KG)

List of abbreviations (with translation)

BMVBS	Bundesministerium für Verkehr, Bau und Stadtentwicklung German Ministry of Transport, Building and Urban Development
BMVBW	Bundesministerium für Verkehr, Bau- und Wohnungswesen German Ministry of Transport, Building and Housing
MSB	Magnetschwebbahn – magnetic levitation system
WEP	Magnetschwebbahn-Weiterentwicklungsprogramm des Bundes Federal development programme of magnetic levitation system
BgmU	Bietergemeinschaft mittelständischer Unternehmen Bidding consortium of medium-sized companies
MbBO	Magnetbahn Bau- und Betriebsordnung German standards for construction and operation of Maglev systems
EBA	Eisenbahn-Bundesamt – Federal Railway Authority
TVE	Transrapid Versuchsanlage Emsland – Emsland Transrapid Test Facility
DB AG	Deutsche Bahn Aktiengesellschaft – German Railways
URE	Umrichtereinheit – converter unit
IGCT	Integrated Gate Commutated Thyristor
MTBF	Mean Time Between Failure (mittlere Zeitdauer bis zum Ausfall der Komponente)
BLT	Betriebsleittechnik – Operations control system
TR {09}	Fahrzeug Transrapid {laufende Versionsnummer} Transrapid vehicle (consecutive numbering of versions)
IPS	Inductive Power Supply (Berührungslose Bordenergieeinspeisung)